

HELUTOP® HT-Clean-EMV (EMC) Stainless steel cable gland

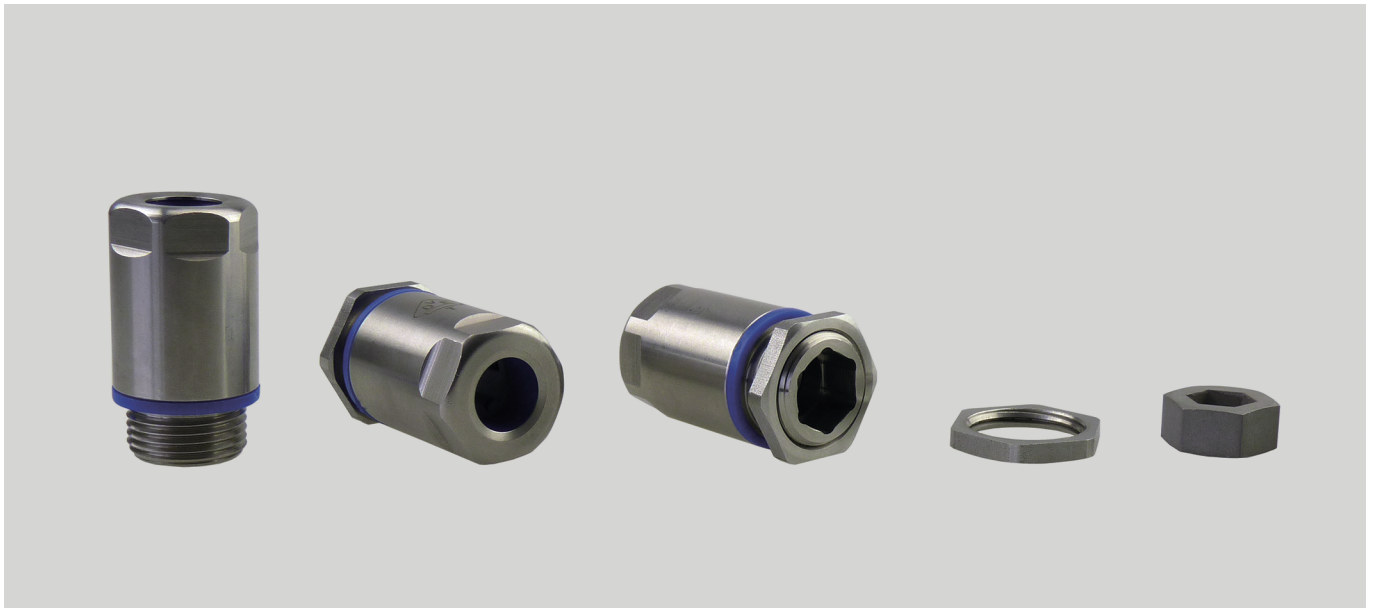

HELUTOP® HT-Clean-EMC

Highest requirements to cleanliness and cleaning.

- EHEDG authorized
- ECOLAB certified

Application

- Food industry - milk and meat products
- Packaging of food machines
- Beverage industry
- Pharmaceutical industry
- Clean room technology
- Biotechnology
- Chemical industry

Material

Stainless steel 1.4305 / AISI 303
Strain relief: POM
Grommet: TPE according to
FDA 21 CFR 177.2600

Properties

- the smooth surface prevents to adhere harmful micro organisms
- easy, fast and less expensive cleaning because of the smooth surface
- suitable for high pressure steam cleanin
- resistant against chemical cleaning supplies
- no threads are exposed
- high tightness
- no enter from water and dirt from outside
- reliable strain relief due to strain relief element separated from grommet

Note

- for tightening from outside use the listed tightening tool
- assembly with commercial socket wrench
- delivery including counter nut

Technical data

Protection class: IP 68-5 bar, 30 min.
according to EN 60529;
IP 69K according to DIN 40050-9

Temperature range: -20°C up to +100°C
Temperature range temporary: -40°C up to +150°C

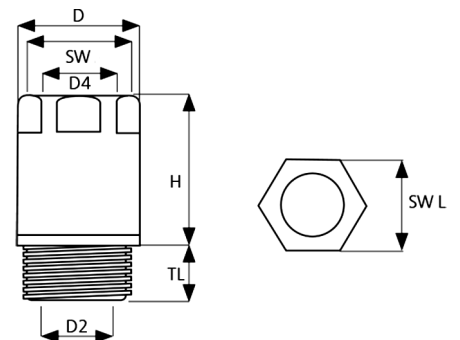

Dimensions

- D Outer diameter of upper part
- D2 Inner diameter of thread
- D4 Inner diameter of upper part
- H Height without thread
- TL Thread length
- SW Spanner size
- SW L Spanner size Counter nut

HELUTOP® Clean-EMV (EMC)

Part no.	Size Metr.	Cable Ø from / to mm	Thread length mm	Spanner size mm	Outer Ø of upper part mm	Inner Ø of upper part mm	Inner Ø of thread mm	Height without thread mm	Recommended Cap Counter nut Nm	Unit	Net EUR/100 items
906918	M16 x 1,5	5,0 - 10,0	7,0	18	20,2	10,3	10	28,5	4	1	o. r.
906919	M20 x 1,5	6,0 - 12,0	10,0	22	24,1	12,3	13	33	5	1	o. r.
906920	M25 x 1,5	12,0 - 17,0	14,0	28	30,1	17,3	17	38	6	1	o. r.

Counter nut Clean-EMV (EMC)

Spanner size mm	Height without thread mm	Recommended Cap Counter nut Nm
15	2,8	6
19	3	9
24	3,5	12
30	4	14

Tightening Tool

Part no.	Size Metr.	Spanner size mm	Height mm	Unit	Net EUR/1 item
906921	M12 x 1,5	5 / 7	5	1	o. r.
906922	M16 x 1,5	6 / 10	5	1	o. r.
906923	M20 x 1,5	8 / 13	8	1	o. r.
906924	M25 x 1,5	10 / 17	8	1	o. r.

Dimensions and specifications may be changed without prior notice.

o. r. = on request